



- ▶ *Industry's Most Powerful and Productive Reclaimer/Stabilizer*
- ▶ *Wider and Deeper Rotor Options Increase Productivity Even More*
- ▶ *Bi-Directional Operation, Highly Maneuverable 4-Wheel Drive, 4-Wheel Steer*

RS800

RECLAIMER/STABILIZER

RS800 | Reclaimer/Stabilizer

Diesel Engine

Caterpillar 3412E DITTA engine. Gross horsepower @ 2,100 rpm, 800 hp (597 kW).

Gross horsepower based on SAE J1349 standard conditions 77°F (25°C) and 29.61 in. hg (100 kPa) using 35 API gravity fuel and engine equipped with fuel, lube oil, and jacket water pumps. No derating required up to 7,054 ft (2,150 m) altitude.

Four-cycle diesel engine with 12 cylinders, 5.4 in (137 mm) bore, 6.5 in (165 mm) stroke and 1,649 in³ (27 liters) displacement. Air cleaner, dry type, two stages with visual service indicator. 24 volt electric starting system with 60 amp alternator. Exhaust muffled with silencer.

Mainframe & Leg Assemblies

Fabricated, heavy-duty, unitized mainframe with engine and cutter center mounted for optimum weight distribution for production and travel. Hydraulically powered leg assemblies (four legs) feature highly versatile parallelogram design which provides 36 in (914 mm) of elevation for raising and lowering machine in and out of cut, and loading and unloading onto trailers for transport.

Elevation control is manual or automatic with the right legs tied together permitting automatic control of cross slope.

Rotary Cutter Assembly

8 ft (2.44 m) wide x 50 in (1.27 m) diameter mandrel. Cutter housing liner group, which includes 0.5 in (1.27 cm) hardened plate hood liner, and 0.75 in (1.9 cm) bolt-on liner plates mounted on cutter housing endplates.

Hydraulic power-up end slides with independent control for right and left sides

Positive displacement lube system which provides lubrication of the lower drive shaft to seal cutter bearing and planetary seal boot. Automatic electric grease pump provides centralized lubrication of the rotating member seals whenever the cutter is engaged.

218 tungsten carbide teeth with 0.75 in (19 mm) shanks. Teeth tap in/tap out for easy replacement. 218 replaceable heavy-duty steel holders on mandrel with unique dowel location system.

Cutting Width 96 in (2,438 mm)
Cutting Depth up to 16 in (406 mm)

Mechanical Rotor Drive System

Wide V-belt power band drives the rotary cutter through a planetary reducer gearbox inside the cutter drum. Dry disc air clutch mounted directly to engine flywheel.

4-speed cutter transmission provides the cutter torque needed in tough applications.

Speed Ranges – 4 Speed Select

- 102 Rotor rpm
- 131 Rotor rpm
- 163 Rotor rpm
- 200 Rotor rpm

Hydraulic System

Hydraulic replenishing tank with 10-micron absolute filtration to pre-filter all hydraulic oil to main reservoir.

Main Tank Capacity 45 gal (170 L)

Hydraulic System Filter 10 micron absolute
Beta₁₀ ≥ 100

Ground Drive Chrg. Oil Filter 12 micron absolute
Beta₁₂ ≥ 200

Wheel & Drive Systems

Transit Speed– 0-5.8 mph (0-9.3 kph)

Working Speed– 0-210 ft/min (0-64 m/min)

Low Range– 0-110 ft/min (0-34 m/min)

Four-Wheel Drive– High torque integral (motor and reducer) wheel drive units are contained within each wheel to provide the tractive effort required for the toughest jobs, and eliminate axles, transmission drive shaft, and associated maintenance requirements.

Four-Wheel Steering– Provides maximum maneuverability via operator selection of coordinated, crab and either pair of leading wheels as required for working or traveling.

Posi-trac– All four wheel drive units are coordinated to propel the machine without slippage by the use of a unique microprocessor based electronic anti-spin control.

Pump– Infinitely variable electrical displacement control with load sensing and pressure protection systems.

Motors– 2-speed, fixed displacement, closed loop with high pressure limiter.

Tires– Drive, wide base ground grip 26.5 x 25 (20PR)

Lights

Two each: Headlights, Job site floodlights, Tail lights, Dash lights.

One each: Beacon light

Brakes

High-powered, fail-safe– Hydraulically actuated parking brakes in front wheel drive. Brakes automatically engage when hydraulic power fails or is shut-off.

Electrical System

24 volt, 60 amp charging circuit, battery disconnect

Service Refill Capabilities

Primary and secondary fuel filters.

Fuel tank 300 gal (1,136 L)
Hydraulic oil tank 45 gal (170 L)
Hydraulic reserve tank 5 gal (19 L)
Cooling system 38.3 gal (145 L)

Steering

Four-wheel steering and four-wheel drive lets operator select coordinated steering (all wheels), crab steering, steering of either leading pair of wheels. Its 17 ft 1 in (5,207 mm) turning radius and 7 in (178 mm) left hand side clearance are the best in the industry.

VALUE ANALYSIS

Industry's Most Powerful -

The RS800's heavy, unitized mainframe with center-mounted 800 hp engine and cutter distribute the machine's 67,500 lb weight and horse-power for the highest possible production while a direct V-Belt driven, four-speed rotor transmission provides the cutter torque needed to tackle tough applications. The V-Belt power bands are up to 25% more efficient than hydro-static drives and they isolate the drive train from cutter generated shock loads for longer component life and less down time.



Full Depth Cutter - The RS800's has the power for optional 20 inch cutting depth and/or optional 10 foot cutting width. Combined with four rotor speed ranges of 102 to 200 rpm, the RS800 is the industry leader for production and best gradation.

Bi-Directional Travel - By changing travel direction, the operator can use the RS800's "up-cut" and "down-cut" capabilities to best advantage while avoiding turns at the end of a working pass. This means the machine spends more time working on the job site and less time maneuvering into position to work. Specifications are easier to achieve because the operator can match working direction and cutter speed range (above) for optimum gradation and blending control while maintaining maximum production.

RS800 | Reclaimer/Stabilizer

Operators Controls

- Modular operator station swivels forward to rearward, 180 degrees providing excellent visibility of the work area in either direction.
- Machine stability and low vibration reduce operator fatigue.
- Highly-visible systems gauges and controls.
- Microprocessor based control system automatically maintains cutting depth, cross slope, and travel speed. Engine load sensing system automatically adjusts travel speed to cutting conditions maintaining optimum use of engine horsepower.
- A 48 character LCD readout provides a continuous display of cutting depth, travel speed and percent of cross slope. The microprocessor also permits a complete online review of all machine operations to assist in operator training and trouble shooting problems in the engine or electrical and hydraulic systems.
- Elevation control is manual or automatic with the right legs tied together permitting automatic control of cross slope.
- Manual backup control system.

Air System

One 18 gal (68 liter) reservoir, one engine mounted compressor, approximately 13 cfm 125 psi (0.37 cu. m/min.) (8.6 bar) safety valve, quick couplers for hook-up on air impact tool.

Optional Equipment

- 58 in (1.47 m) diameter cutter mandrel for 20 in (508 mm) cutting depth.
- Water/Emulsion Spray System – Manual and Automatic 30-500 gal/min (114-1,893 L/min) with flowmeter.
- Fully computerized, automated, self-heating Expanded Asphalt Distribution System.
- Combination heated Expanded Asphalt and 500 gal/min (1893 L/min) Compaction Water System.
- Automatic Cross Slope System.
- 10 ft C10 or quick change cutter mandrel
- Kennametal quick change random pattern cutter mandrel.
- Tow hook attachment–rear (bolt-on).

Important note: all electrical specifications used herein refer to U.S. standards of voltage and frequency. Any electrical equipment that is factory installed will be compatible with power availability requirements of any customer's country.

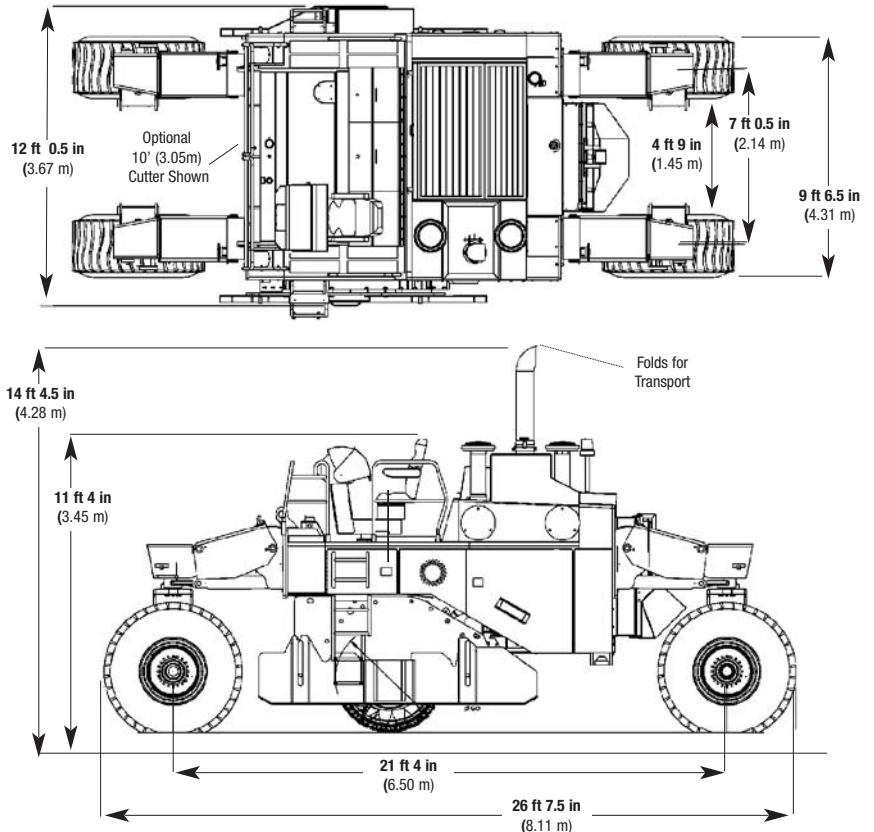

Operating Dimensions

Wheel Base	20 ft 4 in - 21 ft 4 in (6.4- 6.5 m)
Wheel Track	7 ft 3.5 in (2.22 m)
Turning Radius	17 ft 1 in (5.2 m)
Processing Width	8 ft (2.43 m)
Operating Height–Maximum (with legs extended)	15 ft 2 in (4.62 m)

Transport Dimensions

*Weight approx.	67,500 lbs (30,620 kg)
Width	9 ft 11 in (3 m)
Length	26 ft 7 in (8.12 m)
*Transportation Height–Min	11 ft 4 in (3.45 m)

**Dimensions will vary depending on options.*

Note: All dimensions and weights provided with standard width cutter. Operating and transportation dimensions and weights will vary depending on selected options.

Material and specifications subject to change without notification.

